

Chaves Ajustáveis

3611P

- Chave ajustável com escala
- Fabricada em aço cromo-vanádio
- Acabamento polido e fosfatizado
- Acionamento por rosca sem fim recartilhada
- Produzida de acordo com a norma DIN 3117



Código	(mm)	H1 (mm)	Comprimento (mm)	
3611-08P	25	8	200	226
3611-18HP	52	18	375	1485



3611P



3611HP

3611H

- Chave ajustável com escala
- Fabricada em aço cromo-vanádio
- Acabamento cromado e polido
- Acionamento por rosca sem fim recartilhada
- Produzida de acordo com as normas DIN 3117

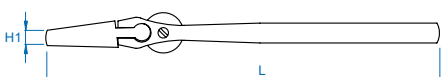

Código	(mm)	H1 (mm)	Comprimento (mm)	
3611-12R	35	13	300	680
3611-15HR	43	13	375	1485

Rosca recartilhada permite fácil ajuste de abertura



3611R



3611HR

3631-10R

- Chave ajustável com catraca
- Fabricada em aço cromo-molibdênio
- Acabamento cromado e polido
- Acionamento por rosca sem fim recartilhada
- Empunhadura em Polipropileno e Borracha Termoplástica (PP+TPR)



Botão R-ON para acionamento de catraca

Cabo ergonômico

Saiba mais:

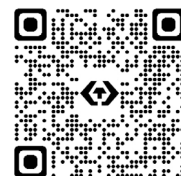

Chave de Aperto com função de catraca
Mecanismo de fácil operação
Trabalhe mais rápido e economize tempo
Indicado para uso em espaços limitados

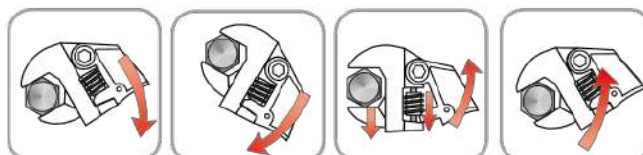

Código	(mm)	Comprimento (mm)	
3631-10R	32	250	597

3641



- Chave gancho ajustável
- Fabricada em aço cromo-vanádio
- Junta equipada com anilha fosfatizada
- Indicada para reparação industrial e aperto de porcas tipo castelo ou chanfradas



Anilha assegura uma operação suave e confiável



Operação em porcas chanfradas

Código	Ajuste (mm)	g
3641-35	13-35	96
3641-50	35-50	166
3641-80	50-80	352
3641-CO	80-120	652
3641-IO	120-180	1260

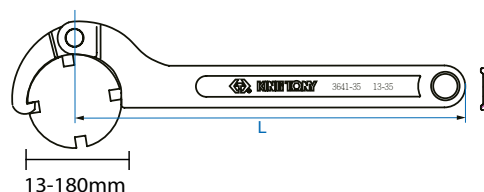

6531

- Chave grifo ajustável para tubos
- Fabricada em aço carbono
- Mordentes paralelos com geometria serrilhada
- Mordentes com acabamento polido
- Empunhadura com pintura epóxi

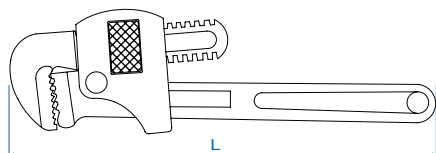
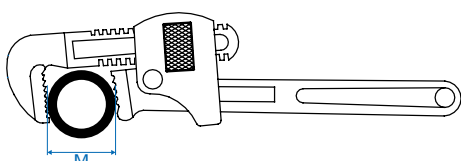



Mordentes paralelos adequados à fixação em qualquer tipo de superfície

Código	L		Abertura(M)		g
	(pol)	(mm)	(pol)	(mm)	
6531-10	10"	229	1"-3/16"	34	600
6531-12	12"	270	1"-9/16"	42	780
6531-14	14"	312	1"-7/8"	48	1050
6531-18	18"	405	2"-3/8"	60	1720
6531-24	24"	541	2"-15/16"	75	3150

Chaves Fixas

1900

- Chave fixa plana *slim*
- Fabricada em aço cromo-vanádio
- Acabamento cromado e polido
- Perfil *slim* (fino) para trabalhos em locais de difícil acesso
- Bocas com bitolas diferentes
- Boca fixa com inclinação de 15°
- Produzida de acordo com a norma DIN 3110

Código	 (mm)	L (mm)	
19000607	6 x 7	123	28
19000809	8 x 9	140	39
19001011	10 x 11	156	65
19001213	12 x 13	172	86
19001415	14 x 15	188,5	114
19001617	16 x 17	204	146
19001819	18 x 19	221	178
19002022	20 x 22	237	210
19002123	21 x 23	247	258
19002224	22 x 24	247	258
19002426	24 x 26	263	281
19002427	24 x 27	263	326
19002528	25 x 28	279	373
19002730	27 x 30	298	481
19003032	30 x 32	298	481

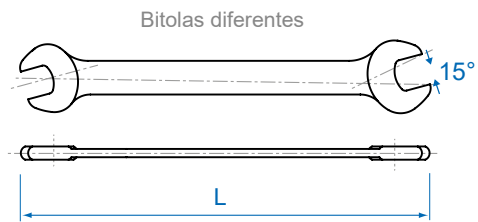

1108 MR

- Jogo de chave fixa slim com 8 peças
- Lona de alta resistência com Velcro®

Código		Composição	
1108MR	1900	6 x 7, 8 x 9, 10 x 11, 12 x 13, 14 x 15, 16 x 17, 18 x 19, 20 x 22	0,91



1112 MR

- Jogo de chave fixa slim com 12 peças
- Lona de alta resistência com Velcro®

Código		Composição	
1112MR	1900	6 x 7, 8 x 9, 10 x 11, 12 x 13, 14 x 15, 16 x 17, 18 x 19, 20 x 22, 21 x 23, 24 x 27, 25 x 28, 30 x 32	2,35



Chaves Combinadas Planas



1060

- Chave combinada plana *slim*
- Fabricada em aço cromo-vanádio
- Acabamento cromado e polido
- Perfil *slim* (fino) para trabalhos em locais de difícil acesso
- Bocas combinadas fixas e estriadas com a mesma bitola
- Bocas fixas e estriadas com inclinação de 15° em relação ao corpo
- King Tony Fix-Drive perfil estriado arredondado para maior torque
- Produzida de acordo com a norma DIN 3113 e ISO 7738

Código	Bitola (mm)	L (mm)	g
1060-06	6.0	105	18
1060-07	7.0	115	20
1060-08	8.0	125	25
1060-09	9.0	135	34
1060-10	10.0	145	39
1060-11	11.0	155	46
1060-12	12.0	165	56
1060-13	13.0	175	69
1060-14	14.0	185	80
1060-15	15.0	195	93
1060-16	16.0	205	111
1060-17	17.0	215	119
1060-18	18.0	225	138
1060-19	19.0	235	158
1060-20	20.0	245	182
1060-21	21.0	255	203
1060-22	22.0	265	225
1060-23	23.0	275	251
1060-24	24.0	285	287
1060-25	25.0	295	326
1060-26	26.0	305	344
1060-27	27.0	315	371
1060-28	28.0	325	387
1060-29	29.0	335	456
1060-30	30.0	345	514
1060-32	32.0	365	557

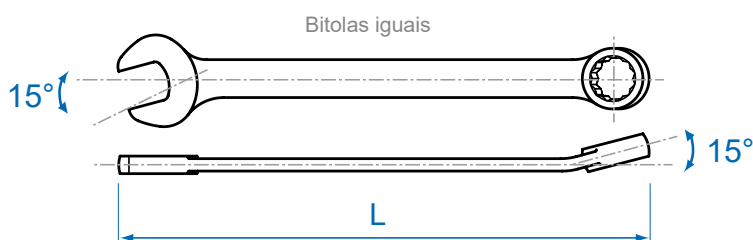

1071

- Chave combinada plana jumbo
- Fabricada em aço carbono de alta qualidade
- Acabamento cromado e polido
- Perfil jumbo para maior resistência
- Bocas combinadas fixas e estriadas com a mesma bitola
- Bocas fixas e estriadas com inclinação de 15° em relação ao corpo
- King Tony Fix-Drive perfil estriado arredondado para maior torque
- Produzida de acordo com as normas DIN 3113, ISO 7738



Código	Tamanho (mm)	L (mm)	g
1071-33	33	410	765
1071-34	34	410	745
1071-36	36	425	960
1071-38	38	455	1155
1071-41	41	495	1402
1071-42	42	495	1453
1071-46	46	495	1515
1071-48	48	563	2550
1071-50	50	563	2550
1071-60	60	645	3000

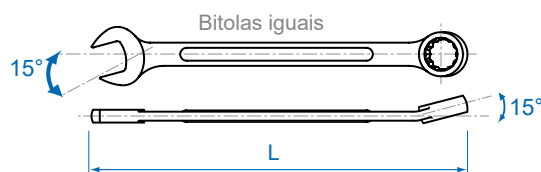

O sistema King Tony Fix-Drive é um design aplicado na produção de soquetes e de chaves de aperto em que se confecciona perfis estriados e sextavados com aristas arredondadas. Isso proporciona uma maior área de contato com o parafuso ou com a porca e transmite maior torque durante a aplicação da ferramenta.



1208

MRS01

Novo

- Jogo de chave combinada plana *slim* com 8 peças
- Suporte para transporte



Código	Composição		kg
1208MRS01	1060	8, 10, 12, 13, 14, 15, 17, 19	0,80



1212

MR

- Jogo de chave combinada plana *slim* com 12 peças
- Lona de alta resistência com Velcro®



Código	Composição		kg
1212MR	1060	8, 9, 10, 11, 12, 13, 14, 15, 16, 17, 19, 22	2,92



1215

MR02

- Jogo de chave combinada plana *slim* com 15 peças
- Lona de alta resistência com Velcro®



Código	Composição		kg
1215MR02	1060	6, 7, 8, 10, 11, 12, 13, 14, 17, 19, 22, 24, 27, 30, 32	2,92



1218

MR01

- Jogo de chave combinada plana *slim* com 18 peças
- Lona de alta resistência com Velcro®



Código	Composição		kg
1218MR01	1060	6, 7, 8, 9, 10, 11, 12, 13, 14, 15, 16, 17, 18, 19, 20, 21, 22, 24	2,50



Embalagem em lona de alta resistência com Velcro®



CHAVES DE APERTO



1226

MR

- Jogo de chave combinada plana *slim* com 26 peças
- Lona de alta resistência com Velcro®

Código	Composição		kg
1226MR	1060	6, 7, 8, 9, 10, 11, 12, 13, 14, 15, 16, 17, 18, 19, 20, 21, 22, 23, 24, 25, 26, 27, 28, 29, 30, 32	5,30



9-90126MR

- Jogo de chave plana *slim* com 16 peças
- Módulo 3 (554 x 260mm)

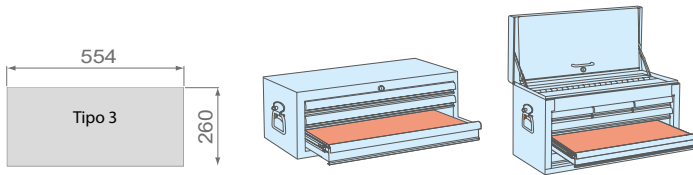

Código	Composição		kg
9-901026MR	1060	6, 7, 8, 9, 10, 11, 12, 13, 14, 15, 16, 17, 18, 19, 20, 21, 22	2,38
	1125MR	H1.5, H2, H2.5, H3, H4, H5, H6, H8, H10	



9-1216MR01

- Jogo de chave plana *slim* com 16 peças
- Módulo 4 (375 x 265mm)

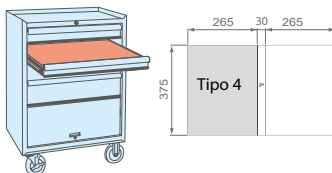

Código	Composição		kg
9-1216MR01	1060	6, 8, 10, 12, 13, 14, 16, 17, 19, 21, 22, 24, 26, 27, 29, 32	3,20



9-1219MR01

- Jogo de chave plana *slim* com 19 peças
- Módulo 4 (375 x 265mm)

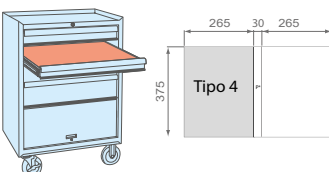

Código	Composição		kg
9-1219MR01	1060	6, 7, 8, 9, 10, 11, 12, 13, 14, 15, 16, 17, 18, 19, 20, 21, 22, 23, 24	2,25



Mini Chaves Planas



10D0

- Mini chave combinada plana
- Fabricada em aço cromo-vanádio
- Acabamento cromado e polido
- Bocas fixas e estriadas com inclinação de 15° em relação ao corpo
- Bocas fixas e estriadas da mesma bitola
- King Tony Fix-Drive perfil estriado arredondado para maior torque
- Produzida de acordo com a norma DIN 3113

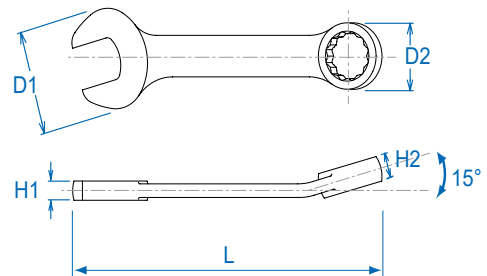

Projetada especialmente para trabalhos em locais com espaço reduzido





Código	 (mm)	D1	D2	H1	H2	L (mm)	
10D0-08	8	18.1	13.8	4.6	6.0	85	20
10D0-09	9	19.3	14.5	4.8	6.4	90	25
10D0-10	10	20.5	15.1	4.8	6.4	95	27
10D0-11	11	22.7	16.7	5.9	7.9	100	45
10D0-12	12	24.7	18.0	6.2	8.3	105	49
10D0-13	13	27.2	19.1	6.5	8.7	110	59
10D0-14	14	28.8	21.4	7.0	9.2	115	65
10D0-15	15	31.0	22.4	7.4	9.7	120	73
10D0-16	16	33.0	23.8	7.8	10.3	125	85
10D0-17	17	35.0	26.2	8.1	10.7	130	116
10D0-18	18	37.0	27.3	8.6	11.3	135	123
10D0-19	19	39.0	28.6	9.0	11.8	140	135

9-1282MR

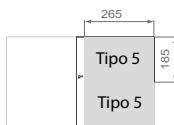
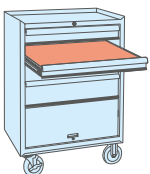
- Jogo de mini chave combinada plana com 12 peças
- Módulo tipo 5 (265x1856mm)



Código	Composição		
9-1282MR	10D0	 8, 9, 10, 11, 12, 13, 14, 15, 16, 17, 18, 19mm	1,05



O sistema King Tony Fix-Drive é um design aplicado na produção de soquetes e de chaves de aperto em que se confecciona perfis estriados e sextavados com aristas arredondadas. Isso proporciona uma maior área de contato com o parafuso ou com a porca e transmite maior torque durante a aplicação da ferramenta.

Jogo Chave Combinada Angulada 45°

9-1272MR



- Jogo de chave combinada angulada 45° com 12 peças
- Fabricada em aço cromo-vanádio
- Acabamento cromado e polido
- Bocas combinadas fixas e estriadas com a mesma bitola
- Boca fixa com inclinação de 15° em relação ao corpo
- Boca estriada com inclinação de 45° em relação ao corpo
- King Tony Fix-Drive perfil arredondado para maior torque
- Produzida de acordo com as normas DIN 3113, ISO 7738 / ISO 3318
- Módulo 4 (375 x 265mm)

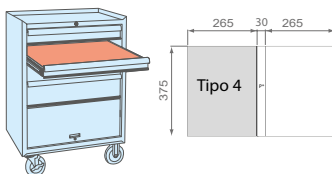
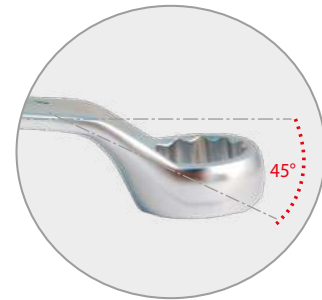
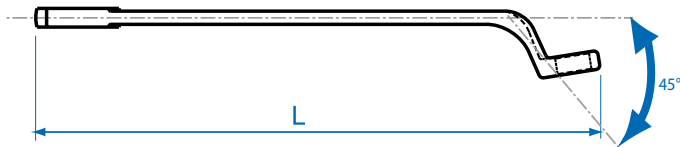

Código	Composição		kg
9-1272MR	1063	 6, 7, 8, 9, 10, 11, 12, 13, 14, 17, 19, 22mm	1,45

Chave Combinada Rápida



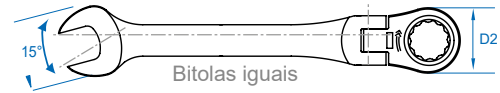

3730 **M**

- Chave combinada rápida articulada
- Fabricada em aço cromo-vanádio
- Acabamento cromado e polido
- Boca estriada com catraca articulada 180°
- Bocas combinadas fixas e estriadas com a mesma bitola
- Catraca com engrenagem de 72 dentes acionada a 5°
- Boca fixa com inclinação de 15° em relação ao corpo
- King Tony Fix-Drive perfil estriado arredondado para maior torque

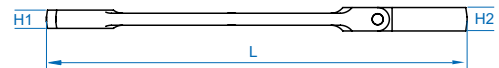

Bitolas iguais



Código	 (mm)	D1	D2	H1	H2	L (mm)	
373008M	8	16.2	16.7	4.3	6.5	127.0	40
373010M	10	20.3	20.0	5.0	7.3	136.0	60
373011M	11	22.5	21.8	5.4	7.7	141.0	60
373012M	12	24.3	23.0	5.8	8.2	147.5	80
373013M	13	26.8	25.2	6.1	8.6	154.0	100
373014M	14	28.7	26.8	6.4	9.0	160.0	100
373015M	15	30.5	28.3	6.9	9.4	169.0	120
373017M	17	34.5	31.8	7.6	10.3	190.0	180
373018M	18	37.0	32.8	8.0	10.7	203.0	200
373019M	19	39.2	33.9	8.6	11.2	215.0	220





Ponta estriada, articulada com catraca

3731 **M**

- Chave combinada rápida plana
- Fabricada em aço cromo-vanádio
- Acabamento cromado e polido
- Boca estriada com catraca
- Bocas fixas e estriadas com a mesma bitola
- Catraca com engrenagem de 72 dentes acionada a 5°
- Boca fixa com inclinação de 15° em relação ao corpo
- King Tony Fix-Drive perfil estriado arredondado para maior torque



Código	 (mm)	D1	D2	H1	H2	L (mm)	
373108M	8	16.7	17.0	4.0	6.5	140.0	25
373109M	9	18.7	18.6	4.4	6.9	149.0	35
373110M	10	20.8	20.2	4.8	7.3	158.0	40
373111M	11	23.0	22.0	5.2	7.7	165.0	60
373112M	12	24.6	23.4	5.5	8.2	171.0	75
373113M	13	26.8	25.5	5.8	8.6	178.0	80
373114M	14	29.0	26.9	6.2	9.0	190.0	100
373115M	15	31.0	28.3	6.5	9.4	199.0	115
373116M	16	33.0	29.8	6.8	9.9	208.0	135
373117M	17	35.5	31.8	7.2	10.3	225.0	165
373118M	18	37.5	32.7	7.7	10.7	236.0	195
373119M	19	39.4	34.0	8.2	11.2	247.0	225
373121M	21	45.8	40.1	9.0	13.0	287.8	320
373122M	22	45.8	40.1	9.0	13.0	287.8	340
373124M	24	51.8	46.5	10.0	14.5	321.0	475

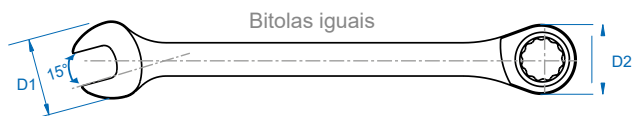

Bitolas iguais



Perfil plano

3732 M





- Chave combinada rápida reversível angulada
- Fabricada em aço cromo-vanádio
- Acabamento cromado e polido
- Bocas estriadas com catraca e mecanismo de reversão
- Bocas fixas e estriadas com a mesma bitola
- Mecanismo de acionamento para sentido normal e reverso
- Catraca com engrenagem de 72 dentes acionada a 5°
- Boca fixa com inclinação de 15° em relação ao corpo
- Boca estriada com catraca com inclinação 13°
- King Tony Fix-Drive perfil estriado arredondado para maior torque

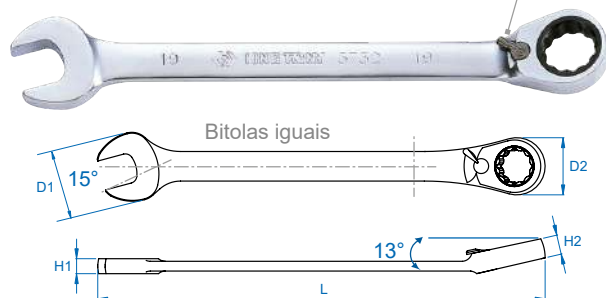

Mecanismo de reversão



Código	 (mm)	D1	D2	H1	H2	L (mm)	
373208M	8	16.7	16.6	4.6	6.5	140	20
373209M	9	18.8	18.4	4.9	6.9	150	25
373210M	10	20.8	20.0	5.3	7.3	159	40
373211M	11	23.0	21.8	5.6	7.7	165	60
373212M	12	25.0	22.7	6.0	8.2	172	75
373213M	13	27.1	24.7	6.4	8.6	178	95
373214M	14	29.2	27.0	6.8	9.0	191	110
373215M	15	31.3	28.3	7.0	9.4	200	120
373216M	16	33.4	30.0	7.2	9.9	208	160
373217M	17	35.5	31.8	7.7	10.3	226	175
373218M	18	37.6	32.6	8.2	10.7	237	205
373219M	19	39.7	33.8	8.8	11.2	248	220



Chaves combinadas/estrelas rápidas com catracas não devem ser utilizadas em operações de aperto ou de desaperto inicial e final, mas sim para agilizar o processo de rosqueamento

3732 R

- Adaptador de soquete para chave combinada e estrela rápida
- Fabricado em aço cromo-vanádio
- Acabamento cromado e polido
- Esfera de segurança para retenção de soquete
- Botão de liberação rápida
- Perfil sextavado ideal para encaixe na catraca

Código		Entrada (mm) Chave	Encaixe (pol)	
373202R		10 mm	1/4"	50
373203R		13 mm	3/8"	70
373204R		19 mm	1/2"	90



Adaptador

Encaixe do adaptador na catraca

Chave combinada rápida com catraca





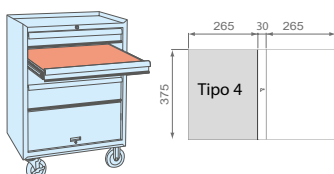

Botão de liberação rápida de soquetes e acessórios

9-12120MR

- Jogo de chave combinada rápida com catraca e adaptador com 10 peças
- Módulo 4 (375 x 265mm)



Código	Composição		
9-12120MR	3731	 8, 10, 12, 13, 14, 15, 17, 19	1.27
	373203R	 Adaptador 3/8"	
	373204R	 Adaptador 1/2"	



Chave Estrela Plana

 19C0



- Chave estrela plana
- Fabricada em aço cromo-vanádio
- Acabamento cromado e polido
- Bocas estriadas com bitolas diferentes
- King Tony Fix-Drive perfil estriado arredondado para maior torque
- Produzida de acordo com a norma DIN 837

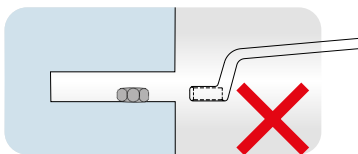

Perfil angular

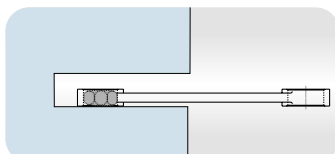

Perfil plano

Código	Tamanho (mm)	L (mm)	
19C00607	6 x 7	121	17
19C00809	8 x 9	137	27
19C01011	10 x 11	154	51
19C01213	12 x 13	164	70
19C01415	14 x 15	182	92
19C01617	16 x 17	211	118
19C01819	18 x 19	226	151
19C02022	20 x 22	240	187
19C02123	21 x 23	255	242
19C02426	24 x 26	270	290

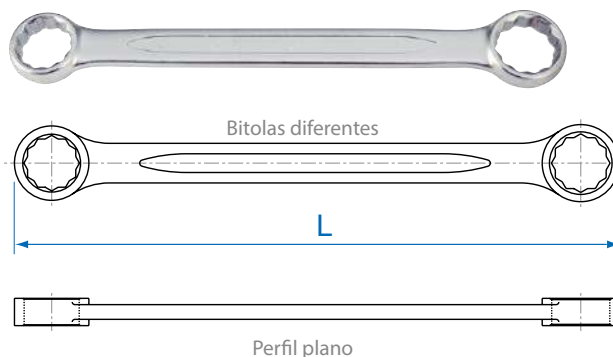



CHAVES DE APERTO

 9-1C08MR

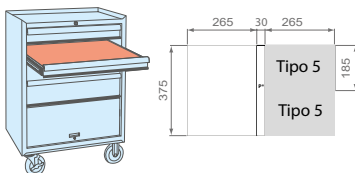
- Jogo de chave estrela plana slim com 8 peças
- Módulo tipo 5 (265x1856mm)



Código	Composição	
9-1C08MR	19C0  6x7, 8x9, 10x11, 12x13, 14x15, 16x17, 18x19, 20x22mm	1.5





O sistema King Tony Fix-Drive é um design aplicado na produção de soquetes e de chaves de aperto em que se confecciona perfis estriados e sextavados com arestas arredondadas. Isso propicia uma maior área de contato com o parafuso ou com a porca e transmite maior torque durante a aplicação da ferramenta.

Mini Chave Estrela Angulada 45°

 1961

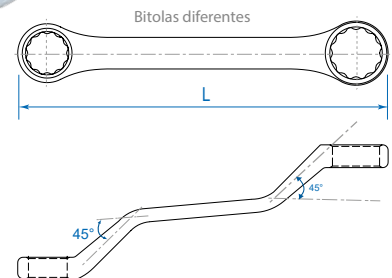
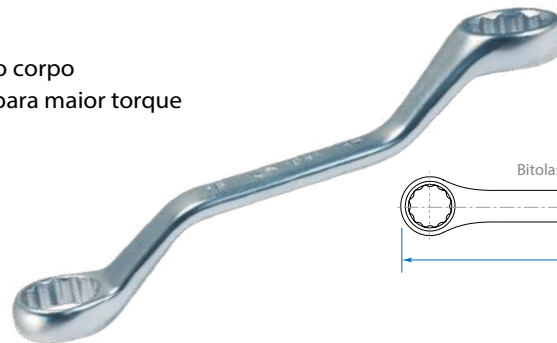
- Mini chave estrela angulada 45°
- Fabricada em aço cromo-vanádio
- Acabamento cromado e polido
- Bocas estriadas com bitolas diferentes
- Bocas estriadas com inclinação 45° em relação ao corpo
- King Tony Fix-Drive perfil estriado arredondado para maior torque
- Produzida de acordo com a norma DIN 838





Código	Tamanho (mm)	L (mm)	
19610809	8 x 9	112	27.6
19611011	10 x 11	115	42.2
19611213	12 x 13	130	57.6
19611415	14 x 15	140	84.0
19611617	16 x 17	150	96.8

Chave Estrela Angulada 45°

 1960

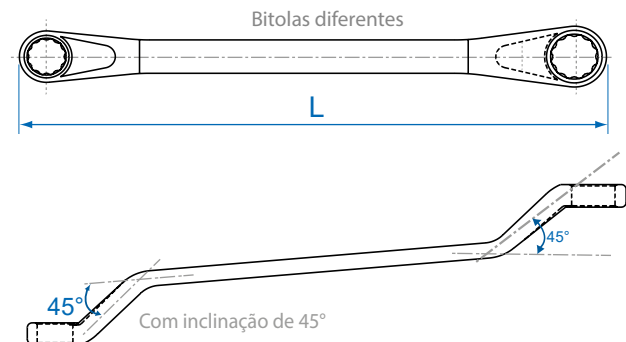
- Chave estrela angulada 45° *slim*
- Fabricada em aço cromo-vanádio
- Acabamento cromado e polido
- Perfil *slim* para locais de difícil acesso
- Bocas estriadas com bitolas diferentes
- Bocas estriadas com inclinação 45° em relação ao corpo
- King Tony Fix-Drive perfil estriado arredondado para maior torque
- Produzida de acordo com a norma DIN 838





Código	Tamanho (mm)	L (mm)	
19600607	6 x 7	165	45
19600809	8 x 9	175	53
19601011	10 x 11	195	60
19601213	12 x 13	205	62
19601415	14 x 15	235	151
19601617	16 x 17	240	151
19601819	18 x 19	250	222
19602022	20 x 22	270	340

 9-1608MR

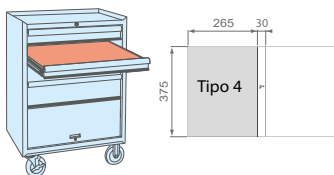
- Jogo de chave estrela angulada 45° *slim* com 8 peças
- Módulo 4 (375 x 265mm)



Código	Composição	
9-1608MR	1960  6x7, 8x9, 10x11, 12x13, 14x15, 16x17, 18x19, 20x22	1.5



Chave Estrela Angulada 75°

 1970



- Chave estrela angulada 75° *slim*
- Fabricada em aço cromo-vanádio
- Acabamento cromado e polido
- Perfil *slim* para trabalhos em locais de difícil acesso
- Bocas estriadas com inclinação 75° em relação ao corpo
- Bocas estriadas com bitolas diferentes
- King Tony Fix-Drive perfil estriado arredondado para maior torque
- Produzida de acordo com a norma DIN 838

Código	Tamanho (mm)	L (mm)	
19700607	6 x 7	168	43
19700809	8 x 9	183	62
19701011	10 x 11	198	88
19701213	12 x 13	217	131
19701415	14 x 15	239	152
19701417	14 x 17	260	186
19701617	16 x 17	260	189
19701719	17 x 19	292	240
19701819	18 x 19	292	240
19702022	20 x 22	318	330
19702123	21 x 23	326,5	362
19702426	24 x 26	329	436
19702427	24 x 27	329	436
19702528	25 x 28	347	488
19703032	30 x 32	362	600

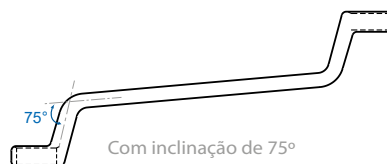
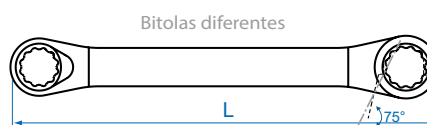

 1708

MR01

- Jogo de chave estrela angulada 75° *slim* com 8 peças
- Lona de alta resistência com Velcro®



Código	Composição	
1708MR01	1970 6 x 7, 8 x 9, 10 x 11, 12 x 13, 14 x 15, 16 x 17, 18 x 19, 20 x 22mm	1,52

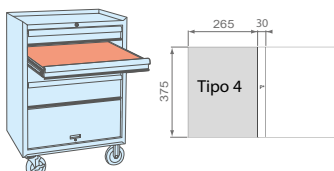

 9-1711MR

- Jogo de chave estrela angulada 75° *slim* com 11 peças
- Módulo 4 (375 x 265mm)



Código	Composição	
9-1711MR	1970  6x7, 8x9, 10x11, 12x13, 14x15, 16x17, 18x19, 20x22, 21x23, 24x27, 30x32mm	2,8



O sistema King Tony Fix-Drive é um design aplicado na produção de soquetes e de chaves de aperto em que se confecciona perfis estriados e sextavados com aristas arredondadas. Isso propicia uma maior área de contato com o parafuso ou com a porca e transmite maior torque durante a aplicação da ferramenta.

Chave Estrela Rápida



12706

MR

- Jogo de chave estrela rápida angulada reversível com 6 peças
- Fabricada em aço cromo-vanádio
- Acabamento cromado e polido
- Bocas estriadas com catraca com inclinação de 13° e mecanismo de reversão
- Bocas estriadas com bitola diferentes
- Catraca com engrenagem de 72 dentes acionada a 5°
- Suporte de plástico para a organização e o acondicionamento de ferramentas
- King Tony Fix-Drive perfil estriado arredondado para maior torque

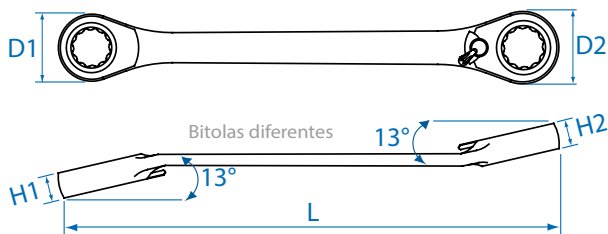

Código		Composição	$\frac{kg}{l}$
12706MR	3737	8 x 9, 10 x 11, 12 x 13, 14 x 15, 16 x 18, 17 x 19mm	0,72

Chaves Para Bater

10A0

- Chave fixa para bater
- Fabricada em aço cromo-molibdênio (24~46) e aço carbono (50~100)
- Acabamento fosfatizado preto
- Projetado para soltar ou apertar porcas e parafusos com o uso de martelo em serviços pesados



Código	Tamanho (mm)	L (mm)	D (mm)	H (mm)	
10A0-24	24	178	52	15	302
10A0-27	27	180	55	16	320
10A0-30	30	190	60	16	400
10A0-32	32	190	61	17	418
10A0-36	36	215	72	17	600
10A0-41	41	233	83	19	902
10A0-46	46	255	94	20	1122
10A0-50	50	275	105	22	1555
10A0-55	55	298	115	24	2015
10A0-60	60	320	127	24	2515
10A0-65	65	340	138	27	3260
10A0-70	70	370	156	32	4390
10A0-75	75	372	153	31	4140
10A0-80	80	395	175	33	6820
10A0-85	85	395	175	33	6300
10A0-90	90	440	197	38	9270
10A0-95	95	440	197	38	8700
10A0-A0	100	480	230	45	10500

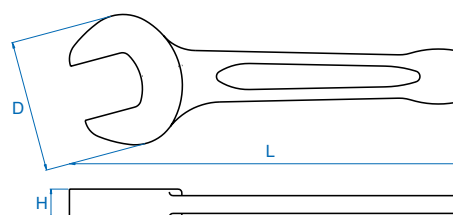

10B0

- Chave estrela para bater
- Fabricada em aço cromo-molibdênio (24~46) e aço carbono (50~100)
- Acabamento fosfatizado preto
- Projetado para soltar ou apertar porcas e parafusos com o uso de martelo em serviços pesados



Código	Tamanho (mm)	L (mm)	D (mm)	H (mm)	
10B0-24	24	162	42	16	239
10B0-27	27	180	46	17	247
10B0-30	30	190	52	18	354
10B0-32	32	190	52	18	404
10B0-36	36	205	58	19	499
10B0-41	41	230	66	21	658
10B0-46	46	240	74	23	886
10B0-50	50	250	78	24	1125
10B0-55	55	265	85	25	1330
10B0-60	60	275	92	26	1245
10B0-65	65	295	100	27	1875
10B0-70	70	325	109	33	2965
10B0-75	75	325	111	34	2735
10B0-80	80	345	126	36	3675
10B0-85	85	345	130	36	3710
10B0-90	90	380	152	40	5850
10B0-95	95	380	152	40	5350
10B0-A0	100	410	155	43	6445

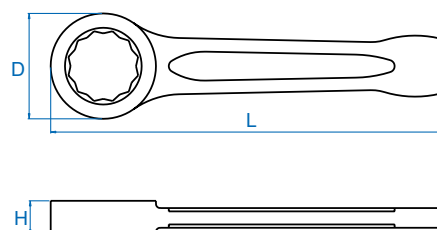

Chaves Biela

1084



- Chave biela
- Fabricada em aço carbono de alta qualidade
- Acabamento cromado
- Modelo permite maior torque sobre o parafuso e maior conforto ao usuário

Código	Ø (mm)	D1 (mm)	D2 (mm)	H1 (mm)	L1 (mm)	L (mm)	g
1084-08	8	12.5	14.0	10	88	230	191
1084-09	9	14.0	15.5	10	88	230	191
1084-10	10	15.0	16.5	10	88	230	191
1084-11	11	16.0	17.5	11	88	230	294
1084-12	12	17.4	19.5	12	98	245	311
1084-13	13	18.9	21.0	12	98	245	395
1084-14	14	19.8	22.0	12	98	260	350
1084-15	15	21.7	24.0	13	98	260	391
1084-16	16	22.2	24.5	13	98	260	388
1084-17	17	24.5	27.0	14	98	260	488
1084-18	18	25.5	28.0	15	98	260	567
1084-19	19	27.1	30.0	15	98	260	595

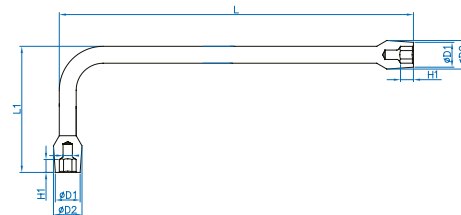

5084



- Chave biela
- Ferramenta em polegadas
- Fabricada em aço carbono de alta qualidade
- Acabamento cromado
- Modelo permite maior torque sobre o parafuso e maior conforto ao usuário

Código	Ø (pol)	D1 (mm)	D2 (mm)	H1 (mm)	L1 (mm)	L (mm)	g
5084-16	1/2"	18.9	21.0	23	12	245	320
5084-18	9/16"	19.8	22.0	23	12	260	336

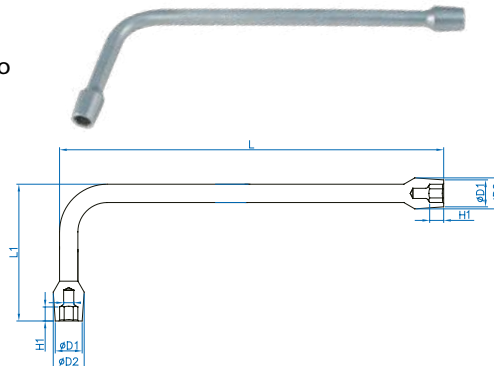

9-1838MR



- Jogo de chave biela com 8 peças
- Módulo 4 (375 x 265mm)

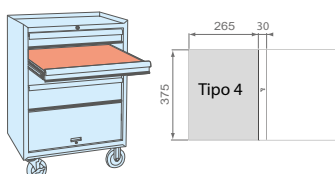

Código	Composição	kg
9-1838MR	1084 8, 10, 11, 12, 13, 15, 17, 19mm	2.57

Chave Biela com Furo Passante

1080

- Chave biela com furo passante estriada e sextavada
- Fabricada em aço carbono de alta qualidade
- Acabamento cromado e polido
- Produzida de acordo com a norma ISO 2236

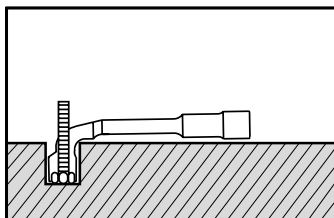

Desenho angulado com furo passante permite trabalhar com parafusos sobressalientes.

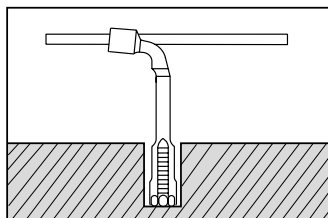

Desenho com o sulco sextavado profundo permite trabalhar com parafusos longos em locais de difícil acesso. O furo passante atua como suporte para um cabo de força.

Código	Ø (mm)	B (mm)	P (mm)	H (mm)	C (mm)	L (mm)	kg
1080-06	6	10.0	7.0	15	29	105	55
1080-07	7	11.5	8.0	15	30	110	60
1080-08	8	12.5	10.0	20	32	120	62
1080-09	9	14.0	10.0	20	33	125	65
1080-10	10	15.0	11.0	20	35	130	100
1080-11	11	16.5	12.0	20	37	135	115
1080-12	12	17.5	12.0	25	40	140	155
1080-13	13	19.0	14.0	25	47	150	180
1080-14	14	20.0	14.0	30	48	160	185
1080-15	15	21.5	15.0	35	50	170	210
1080-16	16	22.5	17.0	35	54	185	285
1080-17	17	24.0	18.0	35	56	195	315
1080-18	18	25.0	19.5	40	58	210	370
1080-19	19	26.5	20.5	40	62	215	425
1080-21	21	29.0	23.5	45	65	230	495
1080-22	22	30.0	23.5	45	67	245	530
1080-24	24	32.5	24.5	45	77	265	670

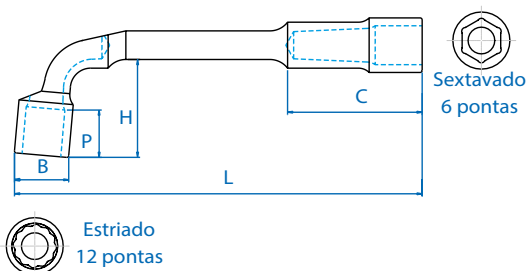

1805 MR

- Jogo de chave biela com furo passante com 5 peças

Código	Ø	Composição	kg
1805MR	1080	10, 11, 13, 14, 17	1,12



1805 MR01

- Jogo de chave biela com furo passante com 5 peças

Código	Ø	Composição	kg
1805MR01	1080	8, 10, 11, 12, 13	0.74



CHAVES DE APERTO

Chave Meia Lua

 1951

- Chave Meia Lua Starter
- Fabricada em aço cromo-vanádio
- Acabamento cromado e polido
- Bocas com bitolas diferentes
- King Tony Fix-Drive perfil arredondado para maior torque

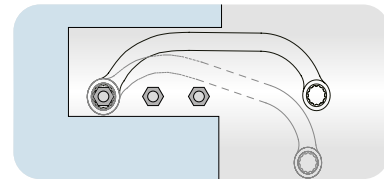

Projetada especialmente para operações de reparação automotiva em locais de difícil acesso

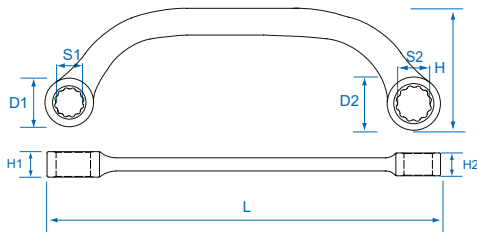



Código	S1 (mm)	S2 (mm)	D1 (mm)	D2 (mm)	L (mm)	H1 (mm)	H2 (mm)	H (mm)	
19510810	8	10	12.5	16.5	125	7.0	7.4	36	48
19511011	10	11	17.5	19	149	8.0	8.5	46	71
19511012	10	12	17.5	19.0	149	8.0	8.5	46	68
19511113	11	13	17.5	19.0	149	8.0	8.5	46	76
19511416	14	16	21.4	23.4	169	8.2	8.4	50	99
19511517	15	17	23.5	27.0	194	9.5	10.0	56	151
19511922	19	22	29.0	32.3	225	11.0	12.0	66	235

Chave Plana Hexalobular

 1920

- Chave plana tipo hexalobular
- Fabricada em aço cromo-vanádio
- Acabamento cromado e polido
- Bocas com bitolas diferentes
- Produzida de acordo com a norma ANSI / ASME B107.6



Código	 (mm)	L (mm)	
19200608	E6 x E8	114.0	19
19201012	E10 x E12	142.5	33
19201418	E14 x E18	183.0	86
19201622	E16 x E22	205.0	119
19202024	E20 x E24	225.0	172

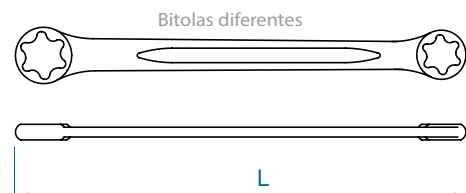

Chave Poligonal Aberta

1930

- Chave poligonal sextavada aberta
- Fabricada em aço cromo-vanádio
- Acabamento cromado
- Bocas sextavadas abertas com bitolas diferentes
- Bocas sextavadas abertas com inclinação de 12° em relação ao corpo
- Indicada para porcas e parafusos de injeção hidráulica, bicos injetores diesel e canos de freios
- Produzida de acordo com a norma DIN 3118

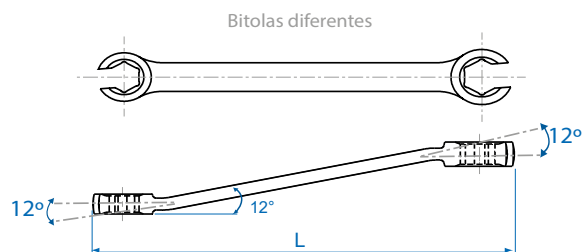

Código	Tamanho (mm)	L (mm)	⚖
19300810	8 x 10	130	53
19301011	10 x 11	150	78
19301113	11 x 13	170	106
19301214	12 x 14	170	102
19301417	14 x 17	190	132
19301719	17 x 19	210	170
19301922	19 x 22	230	218

5930

- Chave poligonal sextavada aberta
- Ferramenta em polegadas
- Fabricada em aço cromo-vanádio
- Acabamento cromado
- Bocas sextavada aberta com bitolas diferentes
- Bocas sextavada aberta com inclinação de 12° em relação ao corpo
- Indicada para porcas e parafusos de injeção hidráulica, bicos injetores diesel e canos de freios
- Produzida de acordo com a norma ANSI / ASME B107.6

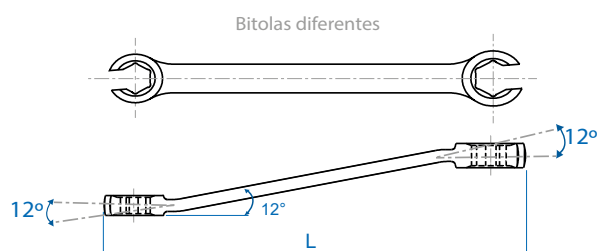

Código	Tamanho (pol)	L (mm)	⚖
59301012	5/16" x 3/8"	130	53
59301214	3/8" x 7/16"	150	78
59301618	1/2" x 9/16"	170	102
59301820	9/16" x 5/8"	190	132
59302224	11/16" x 3/4"	210	170
59302428	3/4" x 7/8"	230	218

1910

- Chave de aperto com soquetes articulados *slim*
- Fabricada em aço cromo-vanádio
- Acabamento cromado
- Bocas com bitolas diferentes
- Soquete articulado 180°
- Soquete estriado com parede fina para trabalhos em locais de difícil acesso

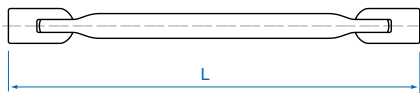

Bitolas diferentes

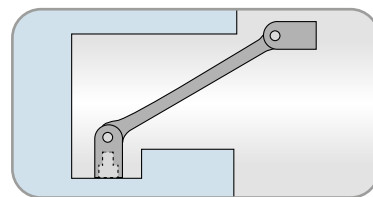

Projetada especialmente para trabalhos em locais de difícil acesso

Código	Tamanho (mm)	L (mm)	
19100607	6 x 7	182	72
19100809	8 x 9	182	78
19101011	10 x 11	200	115
19101213	12 x 13	220	155
19101415	14 x 15	240	235
19101617	16 x 17	259	330
19101819	18 x 19	275	410

Chave Cabo T

1185 M

- Chave cabo T com soquete sextavado fixo
- Fabricada em aço cromo-vanádio
- Acabamento cromado e polido
- Produzida de acordo com a norma DIN 475



Código	D (mm)	ℓ (mm)	L (mm)	
118508M	8	200	250	186
118510M	10	200	250	228
118511M	11	200	250	234
118512M	12	250	250	386
118513M	13	250	300	421
118514M	14	250	300	429
118517M	17	300	300	710

